

CHILLKING Chiller Systems

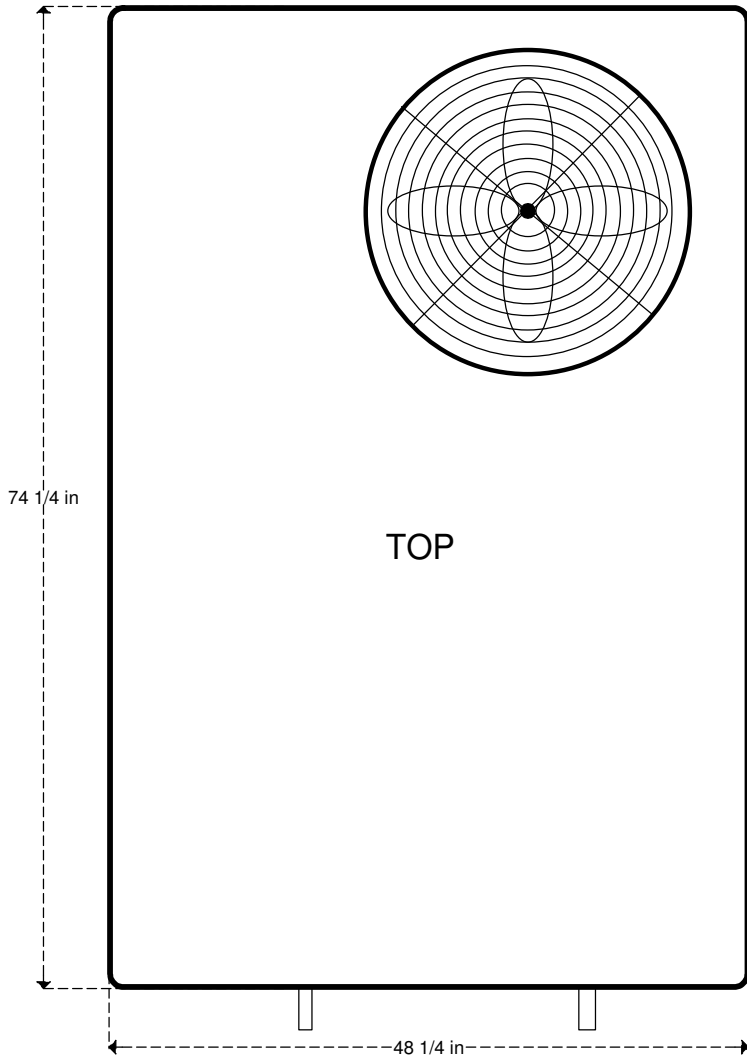

MODEL GCLT60B29KCK3

SPECIFICATIONS:

- Low temperature chiller
- 30,000 BTU/HR at 90F degree ambient and 28F degree water out
- Electrical: 208/230V, 60hz three phase
- Minimum Circuit Ampacity: 29, Maximum Fuse Size 44 Amps
- One 44 gallon stainless steel tank with Chillking evaporator coil inside
- 1 HP water pump: 47 GPM max, 49 PSI max
- R410a Refrigerant
- One 60,000 BTU/HR Copeland scroll compressor
- Approximate shipping weight 900 LBS
- Dimensions: 48-1/4" wide, 74-1/4" long, 38-3/4" tall
- Decibels: 78

FRONT

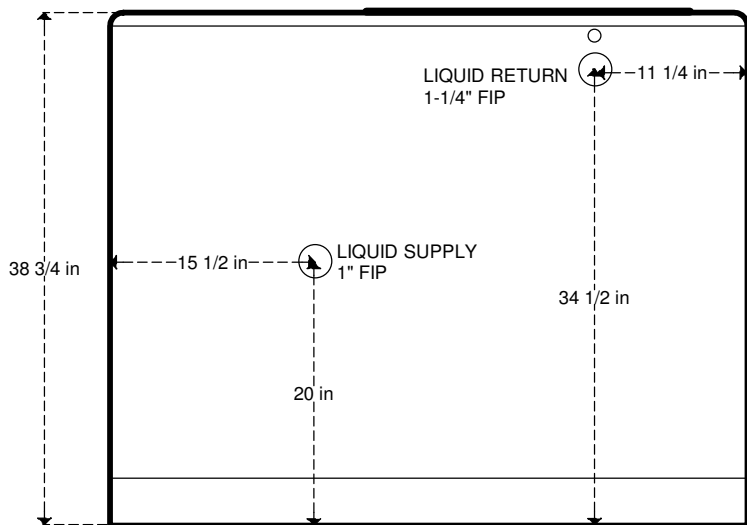

REAR

